



Application Date : 13th Sept., 1938. No. 3978/38.

Applicant (Assignee of Actual Inventor) .. VALSTS ELEKTROTECHNISKA FABRIKA.  
Actual Inventor .. .. . WALTER ZAPP, of Latvia.  
Application and Complete Specification .. Accepted, 8th March, 1939.  
Acceptance Advertised (Sec. 50) .. 23rd March, 1939.

**Classes 52.1 ; 52.2.**

*Drawing attached.*

COMPLETE SPECIFICATION.

**“Improvements in photographic apparatus.”**

We, VALSTS ELEKTROTECHNISKA, FABRIKA, a State Company of Latvia, incorporated under the Laws of Latvia, of Brivibas gatve 19, Riga, Latvia, Manufacturers, hereby declare this invention and the manner in which it is to be performed to be fully described and ascertained in and by the following statement:—

The present invention relates to improvements in photographic roll film cameras.

One object of the invention is to produce a photographic roll film camera of simple construction, in which the tensioning of the shutter and the feeding of the film are effected by the same operation.

Another object of the invention is to produce a photographic roll film camera of such small dimensions that it may be carried in the vest pocket.

Another object of the invention is to construct the camera in such manner that protruding portions are avoided as much as possible; more particularly the usual rotatable handle for feeding the film is eliminated.

Another object of the invention is to construct the camera in such manner that

the lens and preferably also the view-finder are protected when the apparatus is not in use.

It has previously been proposed in photographic cameras intended to contain perforated film, to operate the film-advancing and shutter setting mechanism simultaneously by a common operating member.

The main feature of the roll film camera according to the invention consists therein, that the casing of the apparatus is composed of two bodies which telescope in each other in a direction perpendicular to the axis of the lens, without breaking the light-tight connection between them, and by relative and linear reciprocating movement, effect the tensioning of the shutter and the feeding of the film.

By pulling the two bodies in a direction away from each other, that, is, by extending the camera, which motion is limited by a suitable stop, the camera is quickly and easily brought into a position ready for recording. In this extended position also the manipulation of the camera is facilitated. After recording (by depressing the

button by which the shutter is released), the camera is contracted by pushing the two bodies together.

One embodiment of the invention is shown 5 in the accompanying drawings, in which:—

Figure 1 is a perspective view showing the photographic camera according to the present invention, in normal position.

Figure 2 is a perspective view showing 10 the same camera in an extended position, ready for use.

Figure 3 is a perspective view showing the same camera from the lower side, the lower wall being still more pulled out to 15 uncover the chambers for the film.

Figure 4 is a longitudinal section through the same camera on a larger scale.

Figure 5 is a plan view showing the upper side of the camera after the upper wall has 20 been broken away.

Figure 6 is a corresponding front view partly in section, showing the shutter after the releasing.

Figure 7 is the same front view but shows 25 the shutter after tensioning.

Figure 8 is a cross section taken on the line VIII—VIII in Figure 5.

Referring now to the drawings, the two bodies forming the casing of the camera are 30 indicated by 1a and 1b. The body 1b is movable in the body 1a. In the figures of the drawings, 2 indicates a button by which the shutter mechanism is released, 3 is a graduated knob for focussing the lens, 4 is a 35 graduated knob for setting the time of exposure (the speed of the shutter), 5 is a window for a graduated disc for counting the number of pictures exposed, 6 is the lens and 7 is a view finder, the ocular of which 40 is indicated by 8, the lens and the view finder both being carried by the body 1b. In Figure 3, the lower side of the inner body 1b is uncovered by withdrawal of the cover 1c, so that the chambers 40 for the film 45 rollers as well as a coupling member 21 for rotating one of said rollers are visible. The withdrawal of the cover 1c is necessary for the loading of the roll film in the camera.

The shutter mechanism now to be 50 described is operated when the two bodies of the casing are drawn apart and pushed together. The shutter consists of a thin sheet metal strip 9 which is connected with the outer body 1a by means of a spring 12. 55 The shutter 9 is slidably mounted in a slot

in the inner body 1b and has an opening 10 movable past the lens 6. The shutter 9 bar an extension formed with a hook 9a. By means of this hook the shutter 9 co-operates with a catch lever 14 mounted on a pin 14a 5 in the inner body 1b and supporting the button 2. A tension spring 14b is connected to the lever 14 in such manner that the left hand end of the lever is yieldingly pressed upwards. 10

Between the shutter 9 and the lens 6 a plate 11 is located which is secured to the outer body 1a and serves to prevent the lens from being uncovered when the camera is being shut. The plate 11 has an opening 15 11a therein.

The shutter 9 also co-operates with a retarding mechanism located in the inner body 1b and comprising a retarding lever 35 mounted upon a pin 39. A torsional 20 spring 39a surrounding the pin 39, is connected to the lever 35 in such manner that it tends to turn the lever 35 in a counter-clockwise direction (Figure 5). This lever 35 carries a toothed segment 35a engaging 25 a gear wheel 36 secured on a toothed wheel 37 co-operating with a double pawl 38. The wheel 36 and the pawl 38 form a mechanism of the well-known clock escapement type. The lever 35 carries a pin 35b projecting 30 through the upper wall of the body 1b and arranged in such manner that it may be engaged by a cam 4a secured to the graduated timing member 4.

The operation is as follows:— 35

Assuming that the camera is shut, then the hook 9a of the shutter 9 is engaged by the catch lever 14. When the camera is extended, that is, when the inner body 1b is moved outwards in the outer body 1a to 40 the position shown in Figure 2, the shutter 9 is also moved in the same direction as the inner body 1b, so tensioning the spring 12 as in Figure 7. When the camera has attained its fully extended position the plate 45 11 presents the opening 11a in front of the lens 6. However, the opening 10 in the shutter 9 does not then lie in front of the lens but beside the same, as shown in Figure 7. Thus, in this position the lens 6 is covered. 50 During the shutting motion the opening 10 in the shutter would uncover the lens if the plate 11 were not provided, to cover the lens during the movement of the opening 10 past the lens 6. 55

If now, the button 2 is depressed, the shutter 9 is released and moves over the lens 6, which will be exposed to the light when the opening 10 of the shutter passes the opening 11a in the plate 11. When the shutter 9 has attained its position of rest, the lens 6 is again covered, as shown in Figure 6. Then the camera may be shut.

In Figure 5 the retarding mechanism for the shutter is shown in the position corresponding to the shortest time of exposure. When the picture is to be exposed for a longer time the cam 4a is turned in a clockwise direction, and for the following description let it be assumed that the cam 4a is directed more downwards in Figure 5. This figure illustrates the lever 35 and the shutter 9 in their positions after the release of the shutter. In this position the hook 9a prevents the lever 35 from being swung about its pin 39 to engagement with the cam 4a by the torsional spring 39a. When the parts 1a and 1b are pushed together the left hand end of the lever 35 is disengaged from the hook 9a and is swung counter-clockwise by the spring 39a. Simultaneously, the wheels 36, 37 are rotated in a clockwise direction by the sector 35a of the lever 35 until the rotation is stopped by engagement of the pin 35b with the cam 4a. This is the initial position of the retarding mechanism and this initial position is determined by the position to which the cam 4a is set. When the camera is now extended nothing occurs except the tensioning of the shutter 9 which in the closed position of the camera is engaged by the catch lever 14. Upon disengagement of the lever 14 by depression of the button 2 the shutter 9 moves freely to the left until it engages the left hand end of the lever 35 which then is swung in a clockwise direction from engagement with the cam 4a until the lever 35 has attained the position shown in Figure 5. During this turning motion the lever rotates the wheels 36, 37 in a counter-clockwise direction, and during this rotation of the wheels controlled by the double pawl 38 in well-known manner, the lens is uncovered by opening 10. Then the shutting motion of the shutter is completed and the lens is covered. Now, the parts 1a and 1b may be pushed together so that the lever 35 may swing to engagement with the cam 4a. Clearly, the time during which the lens is

uncovered is dependent upon the position from which the lever 35 begins its rotation in a clockwise direction.

Feeding of the film is effected by the reciprocating motion. For this purpose, there is attached to the outer body 1a a member 19 which in the embodiment shown is formed as a rack. The film feeding mechanism is located in the inner body 1a and comprises a plate 20 provided with 10 teeth 20a and having an arm 31 for cooperation with the rack 19. The plate 20 is connected with the coupling member 21 for the film roller by means of a unidirectional feeding and stop mechanism comprising two helical springs 23, 24 (Figure 8); when the plate 20 is rotated in one direction, the coupling member 21 is also rotated, but when the plate 20 is rotated in the opposite direction, the coupling member 21 is prevented from rotating backwards. When the two bodies of the casing are pushed together, the plate 20 is rotated by the rack 19 which operates first the arm 31 and then the toothed portion of the plate 20 to feed the film. The spring 30 is tensioned. During this movement, a spring plate 33 on the rack 19 engages the disc 5 for counting the pictures, and moves it through one step. A helical cam 50 is attached to the disc 5. By this, a lever 29 is turned and a stop 29a formed on the end of this lever is carried forwards a certain distance into the path of motion of a projection 32 on the plate 20. When the two bodies of the casing are pulled apart, the plate 20 is rotated backwards, first by the teeth on the rack 19 and then by the spring 30 until the projection 32 engages the stop 29a. The film feeding mechanism is thus brought into position for the next feeding movement of the film. By reason of the fact that for each reciprocating motion of the rack 19 the stop 29a is moved forwards a certain distance, a compensation for the increase of diameter of the film roll is attained.

When the camera is closed the lens 6 together with the view finder 7 and ocular 8 are covered by the outer body 1a. The lens and view finder, with the ocular are uncovered only when the camera is extended, the lens by an opening 70 in the body 1a, and the view finder and ocular by reason of the fact that they then lie outside the outer body 1a, as seen in Figure 2.

The film 26 is pressed against the picture window, only when the apparatus is in its extended position. For this purpose, a plate 16 (Figure 4) is mounted behind the lens 5 in an opening in the inner body 1b and is movable to and from the film 26. The outer body 1a has an inwardly extending projection 18 in such position that it lies opposite to the plate 16 when the apparatus is extended. By means of a spring 17, said projection 18 then presses the plate 16 against the film, which is thus pressed against the picture window.

Having now fully described and ascertained our said invention and the manner in which it is to be performed, we declare that what we claim is:—

1. A photographic roll film camera having a casing comprising two bodies which telescope in each other in a direction perpendicular to the axis of the lens, without breaking the light-tight connection between them, and by relative and linear reciprocating movement effect the tensioning of a shutter for the lens and the feeding of a film inserted in the camera.

2. A photographic roll film camera according to Claim 1, having a releasable catch mechanism for retaining the shutter under tension, and feeding mechanism for the film, located in one of said bodies, the

shutter as well as an operating member for the feeding mechanism being attached to the other body, the attachment of the shutter being by means of a spring.

3. A photographic roll film camera according to Claim 1, wherein the lens is covered or obscured when the two bodies are pushed together but is exposed when they are pulled apart.

4. A photographic roll film camera according to Claim 1, having a view finder which is covered or obscured when the two bodies are pushed together but is exposed when they are pulled apart.

5. A photographic roll film camera according to Claim 1, wherein the film is automatically pressed against a picture window when the extending movement of the casing is completed.

6. A photographic roll film camera having the working parts contained in and operable by an extensible casing substantially as hereinbefore described with reference to the accompanying drawings.

Dated this 12th day of September, A.D. 25 1938.

CECIL W. LE PLASTRIER,  
Phillips, Ormonde, Le Plastrier & Kelson,  
Patent Attorneys for Applicant.

Witness—L. Spinks.

FIG. 1.

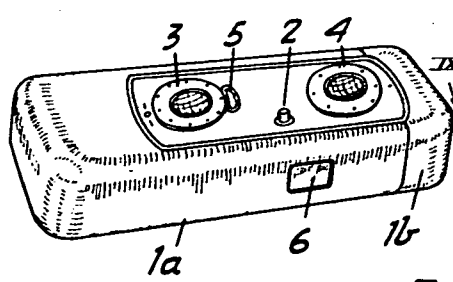

FIG. 2.

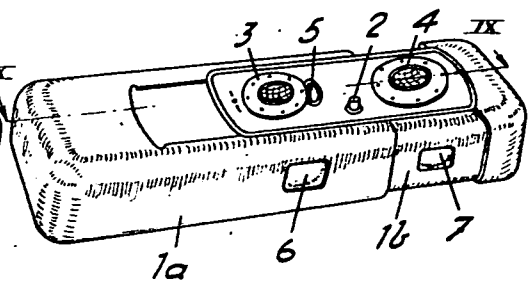

FIG. 3.

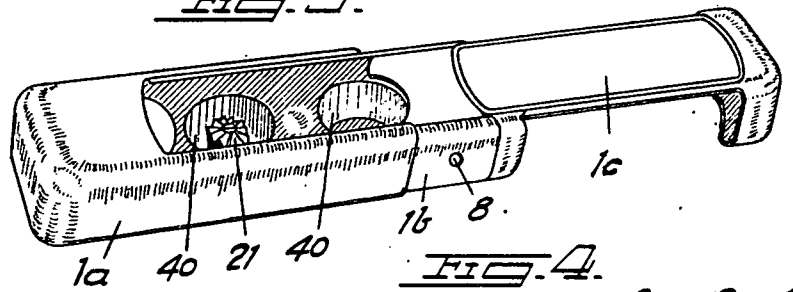

FIG. 4.

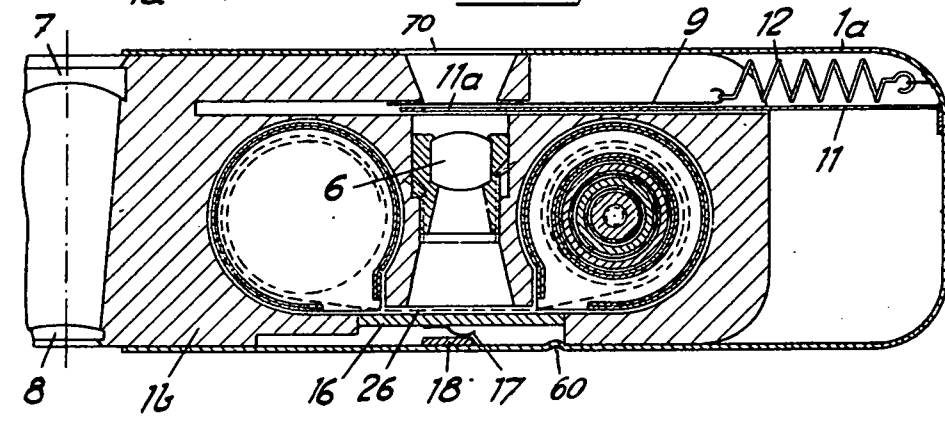

FIG. 5.

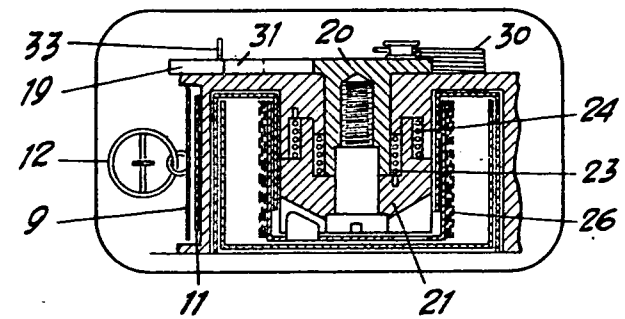

FIG. 5.

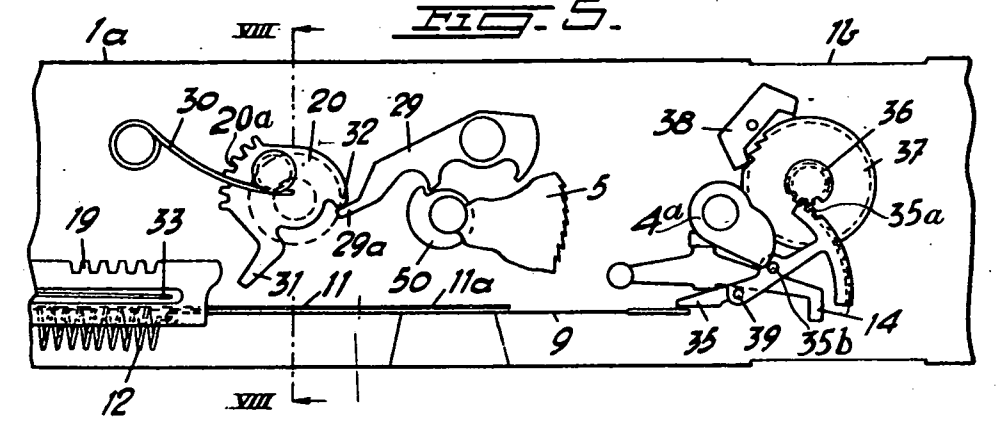

FIG. 6.

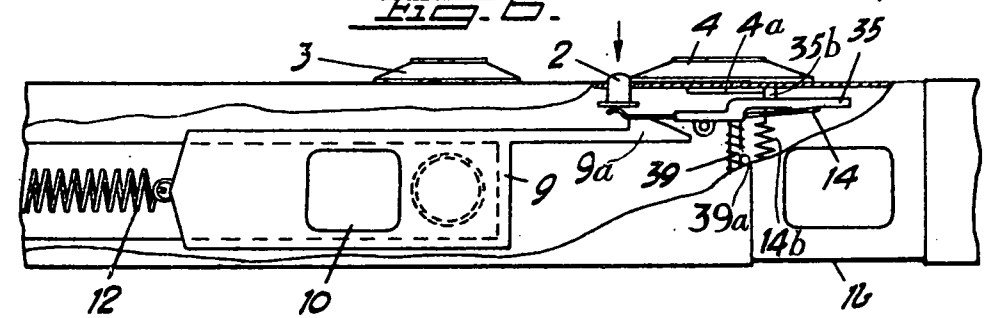

FIG. 7.

