

GOVERNMENT OF INDIA.

THE PATENT OFFICE.

1, COUNCIL HOUSE STREET, CALCUTTA.

SPECIFICATION

No. 25685. Filed 15th September 1938.

Reciprocity date (United Kingdom)—2nd December 1937.

ACCEPTED 15TH DECEMBER 1938.

IMPROVEMENTS IN PHOTOGRAPHIC APPARATUS.

VALSTS ELEKTROTECHNISKA FABRIKA, A STATE COMPANY OF
LATVIA, INCORPORATED UNDER THE LAWS OF LATVIA, OF BRIVIBAS GATVE
19, RIGA, LATVIA.

*The following specification particularly describes and ascertains the nature of the
invention and the manner in which the same is to be performed.*

The present invention relates to improvements in photographic
apparatus.

One object of the invention is to produce a photographic apparatus of
simple construction, in which the tensioning of the shutter and the feeding
of the film are effected by the same operation. 5

Another object of the invention is to produce a photographic apparatus
of such small dimensions that it may be carried in the vest pocket.

Another object of the invention is to construct the apparatus in such
manner that protruding portions are avoided as much as possible; more
particularly the usual rotatable handle for feeding the film is eliminated. 10

Another object of the invention is to construct the apparatus in such
manner that the lens and preferably also the view-finder are protected when
the apparatus is not used.

The main feature of the apparatus according to the invention consists
therein, that the casing of the apparatus is composed of two bodies which
are adapted to reciprocate one in the other perpendicularly to the axis of
the lens, the tensioning of the shutter and the feeding of the film being
effected by this reciprocating movement. 15

By pulling the two bodies in a direction away from each other, that
is, by extending the apparatus, which motion is limited by a suitable stop,
the apparatus is brought into a position ready for recording. In this
extended position also the manipulation of the apparatus is facilitated.
After recording (by depressing the button by which the shutter is released),
the apparatus is contracted by pushing the two bodies together. 20

One embodiment of the invention is shown in the accompanying drawings,
in which :— 25

Figure 1 is a perspective view showing the photographic apparatus
according to the present invention, in normal position.

Figure 2 is a perspective view showing the same apparatus in an
extended position, ready for use. 30

Figure 3 is a perspective view showing the same apparatus from the
lower side, the lower wall being still more pulled out to uncover the chambers
for the film.

25685

Price: ONE RUPEE.

Figure 4 is a longitudinal section through the same apparatus on a larger scale.

Figure 5 is a plan view showing the upper side of the apparatus after the upper wall has been broken away.

Figure 6 is a corresponding front view partly in section, showing the shutter after the releasing.

Figure 7 is the same front view but shows the shutter after tensioning.

Figure 8 is a cross section taken on the line VIII—VIII in Figure 5.

Referring now to the drawings, the two bodies forming the casing of the apparatus are indicated by 1a and 1b. The body 1b is movable in the body 1a. In the figures of the drawings, 2 indicates a button by which the shutter mechanism is released, 3 is a graduated scale for setting the lens to different distances, 4 is a graduated scale for setting the times of exposure (the speed of the shutter), 5 is a window for a graduated disc for counting the number of the pictures exposed, 6 is a lens and 7 is a view finder, the ocular of which is indicated by 8. In Figures 3, the lower side of the inner body 1b is uncovered by withdrawal of the cover 1c, so that the chambers 40 for the film rollers as well as a coupling member 21 for rotating one of said rollers are visible.

The shutter consists of a thin sheet metal strip 9 which is connected with the outer body 1a by means of a spring 12 and is slidably mounted in the inner body 1b. The shutter has an opening 10 (Figure 6) movable past the lens 6. By means of a hook 9a, the shutter 9 co-operates with a catch lever 14 mounted in the inner body 1b and supporting the button 2. Between the shutter 9 and the lens 6, a plate 11 is located which is secured to the outer body 1a and serves to prevent the lens from being uncovered when the shutter mechanism is being tensioned. Assuming that the apparatus is shut, then the hook 9a of the shutter 9 is engaged by the catch lever 14. When the apparatus is extended, also the shutter 9 is moved in the same direction as the inner body 1b, tensioning the spring 12. When, however, the apparatus has attained its fully extended position, the plate 11 presents an opening 11a (Figure 5) in front of the lens 6. If, now, the button 2 is depressed, the shutter 9 is released and moves over the lens 6, which will be exposed to the light when the opening 10 of the shutter passes the opening 11a. During this releasing motion, the shutter 9 moves over an adjustable retarding mechanism 35-39 of well-known type located in the inner body 1b. The apparatus may now be shut. During this motion, the opening 10 in the shutter 9 would uncover the lens if the plate 11 were not provided.

Also the feeding of the film is effected by the reciprocating motion. For this purpose, to the outer body 1a a member 19 is attached which in the embodiment shown is formed as a rack. The film feeding mechanism is located in the inner body 1b and comprises a toothed plate 20 having an arm 31. The plate 20 is connected with the coupling member 21 for the film roller, which connection consists of a unidirectional feeding and stop mechanism comprising two helical springs 23, 24 (Figure 8); when the plate 20 is rotated in one direction, also the coupling member 21 is rotated, but when the plate 20 is rotated in the opposite direction, the coupling member 21 is prevented from rotation backwards. When the two bodies of the casing are pushed together, the plate 20 is rotated by the rack 19 which operates first the arm 31 and then the toothed portion of the plate 20. The spring 30 is tensioned. During this movement, a spring plate 33 on the rack 19 engages the disc 5 for counting the pictures, to which disc a helical cam 50 is attached. By this action, a lever 29 is turned and a stop 29a formed on the end of this lever is carried forwards a certain distance into the path of motion of a projection 32 on the plate 20. When the two bodies of the casing are pulled apart, the plate 20 is rotated backwards, first by the teeth on the rack 19 and then by the spring 30 until the projection 32 engages the stop 29a. By reason of the fact that for each reciprocating motion of the rack 19 the stop 29a is moved forwards a certain distance, a compensation for the increase of diameter of the film roll is attained.

The film 26 is pressed against the picture window, only when the apparatus is in its extended position. For this purpose, a plate 16 (Figure 4) is mounted in an opening in the inner body 1b and is movable to

and from the film 26. The outer body 1a has an inwardly extending projection 18 in such position that it lies opposite to the plate 16 when the apparatus is extended. By means of a spring 17, said projection 18 then presses the plate 16 against the film, which is thus pressed against the picture window.

We claim:

1. A photographic apparatus having a casing comprising two bodies which are adapted to reciprocate one in the other in a direction perpendicular to the axis of the lens, such reciprocating movement being utilized to effect the tensioning of a shutter for the lens and the feeding of a film inserted in the apparatus. 5
2. A photographic apparatus according to Claim 1, having a releasable catch mechanism (a tensioning mechanism) for the shutter as well as a feeding mechanism for the film, located in one of said bodies, the shutter as well as an operating member for the feeding mechanism being attached to the other body, the former by means of the shutter spring. 10
3. A photographic apparatus according to Claim 1, wherein the lens is protected when the two bodies are pushed together, but is uncovered when they are pulled apart. 15
4. A photographic apparatus according to Claim 1, having a view finder which is protected when the two bodies are pushed together but is uncovered when they are pulled apart. 20
5. A photographic apparatus according to Claim 1, wherein the film is automatically pressed against a picture window when the two bodies are moved relatively to extend the casing and such movement is completed.
6. A photographic apparatus having the working parts contained in and operable by an extensible casing substantially as hereinbefore described with reference to the accompanying drawings. 25

VALSTS ELEKTROTECHNISKA FABRIKA.

By its Attorneys,
REMFREY & SON.

Dated this 15th day of September 1938.

FIG. 1.

FIG. 2.

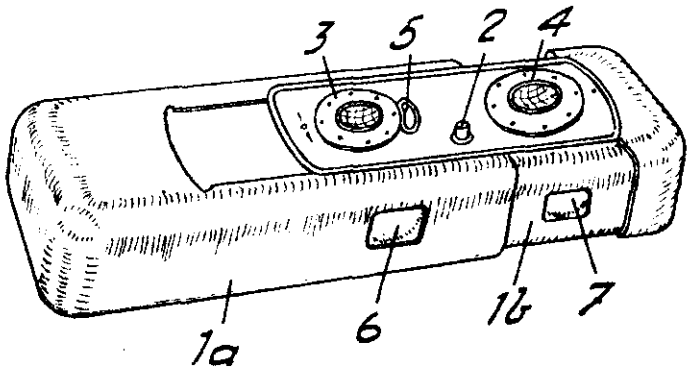
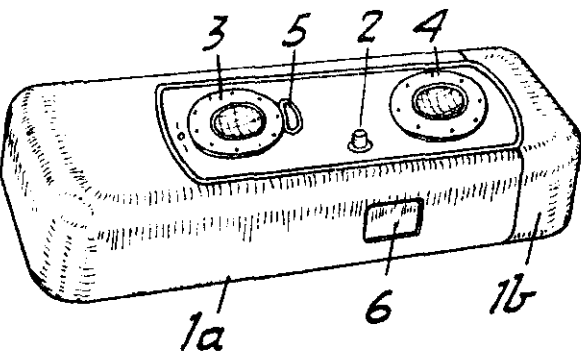

FIG. 3.

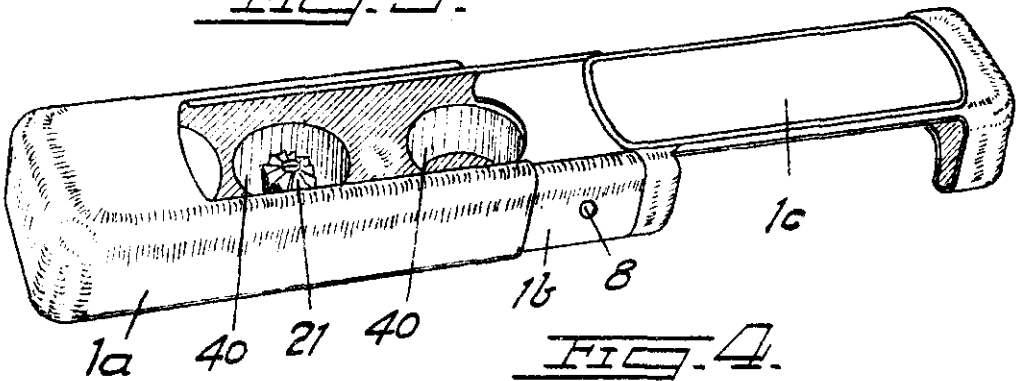

FIG. 4.

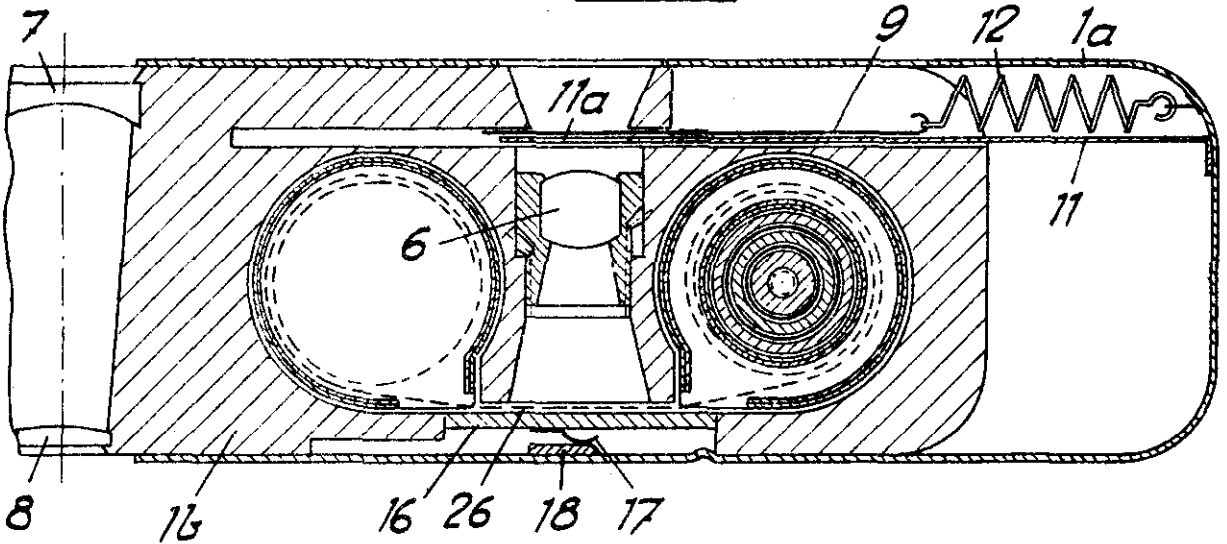
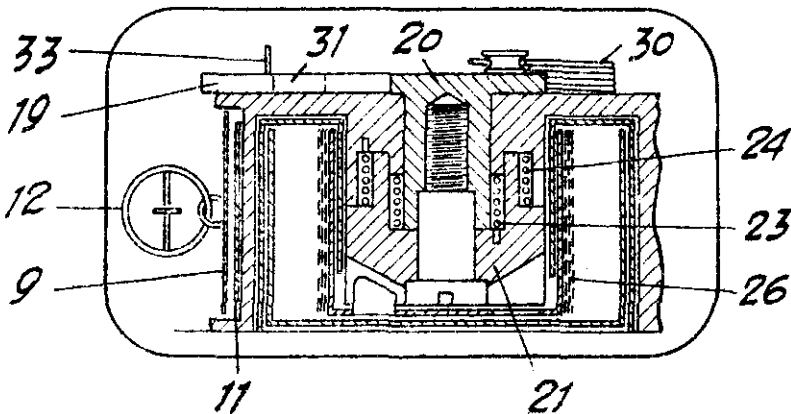

FIG. 5.



NO. 25685 of 1938.

FIG. 5.

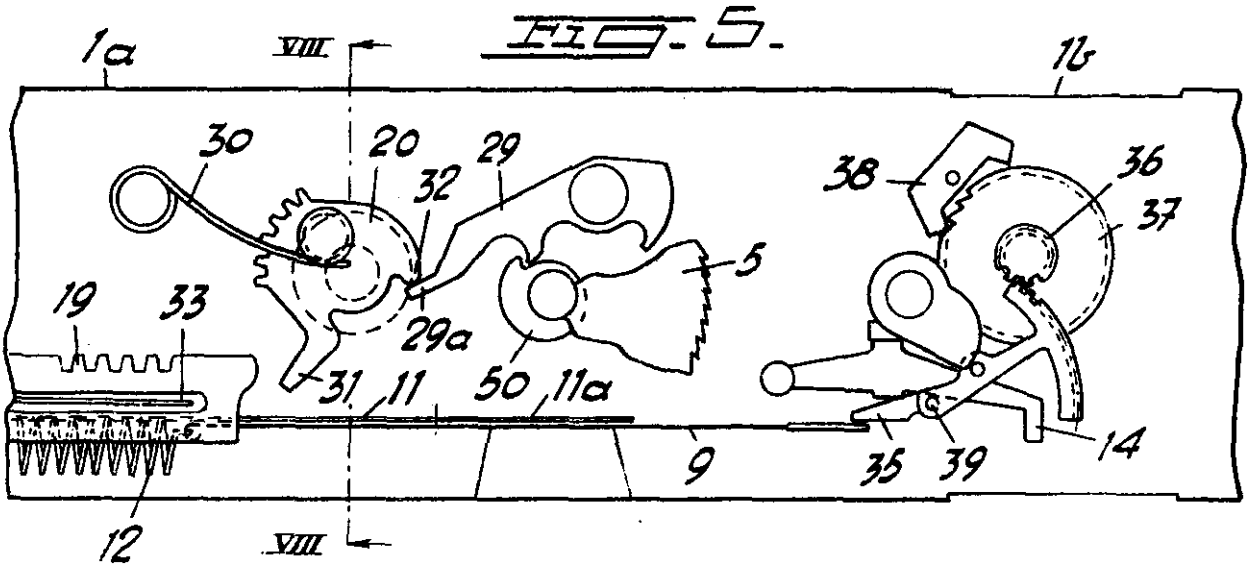

FIG. 6.

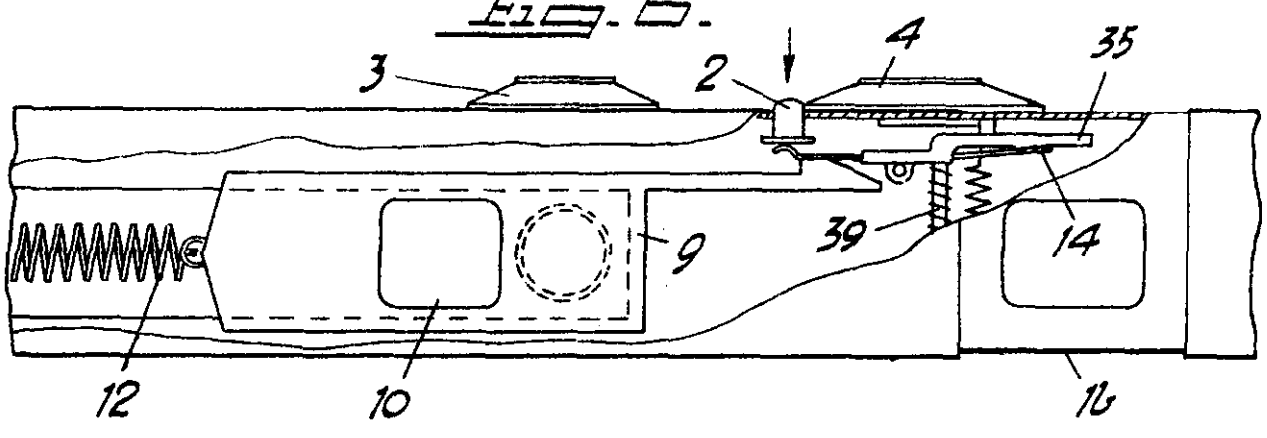

FIG. 7.

